

Recovery of Thermally Marked Otoliths from Lake Trout Stocked as Fry in Lake Superior¹

Mary T. Negus

Minnesota Department of Natural Resources
Division of Fisheries
500 Lafayette Road
St. Paul, MN 55155-4012

Abstract.--Lake trout *Salvelinus namaycush* fry with thermal marks in their otoliths were stocked annually at Sve's Reef in Lake Superior from 1994 to 1996 in an attempt to supplement lake trout populations that include both naturally reproduced fish and those stocked as fin-clipped yearlings. Lake trout from these year classes were sampled during annual gill net assessments from 2000 to 2002, and otoliths from unclipped lake trout captured near the stocking reef were processed and examined for the presence of a thermal mark. Thermal marks were identified in otoliths from 21 fish out of 836 examined. The accuracy of mark identification was confirmed by examining and correctly identifying otoliths from a random mixture of hatchery-reared marked fish and recaptured clipped lake trout (without thermal marks). While thermal marks are relatively simple and inexpensive to apply to large numbers of fry, mark retrieval is more labor-intensive and time-consuming. Many otoliths were examined from fish in non-target year-classes due to the wide overlap in size-at-age of this species. Most lake trout in the targeted year-classes were immature.

Introduction

Approximately 1,450,000 lake trout *Salvelinus namaycush* fry with thermal marks in their otoliths were stocked annually onto Sve's Reef in Lake Superior near the Split Rock River from 1994 to 1996 (Negus 1998, 1999; Negus and Dexter 1995; Figure 1, Figure 2). To evaluate the success of fry stocking, survivors had to be identified among captured lake trout that also included naturally reproduced fish, and those stocked as fin-clipped yearlings. All lake trout stocked as

yearlings received a fin clip indicating year-class, but distinguishing the fry-stocked thermally-marked fish from naturally reproduced fish required examination of otoliths from fish within the size range appropriate for the target year-classes. While thermal marking is a relatively simple and inexpensive technique that is accomplished without handling individual fish (Brothers 1990; Volk et al. 1990; Munk et al. 1993), mark retrieval is more labor-intensive and time-consuming, and requires the sacrifice of a fish and otolith extraction, preparation, and examination.

¹ This project was funded in part by the Federal Aid in Sport Fishing Restoration (Dingell-Johnson) Program. Completion Report, Study 660. D-J Project F-26-R Minnesota.

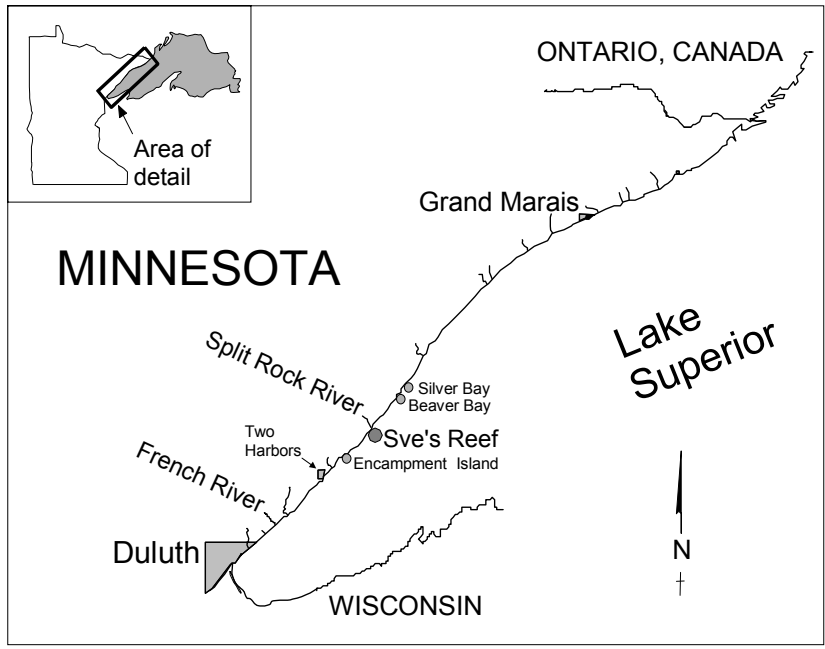

Figure 1. Lake trout assessment netting locations in Lake Superior, where otoliths were obtained for aging and thermal mark evaluation.

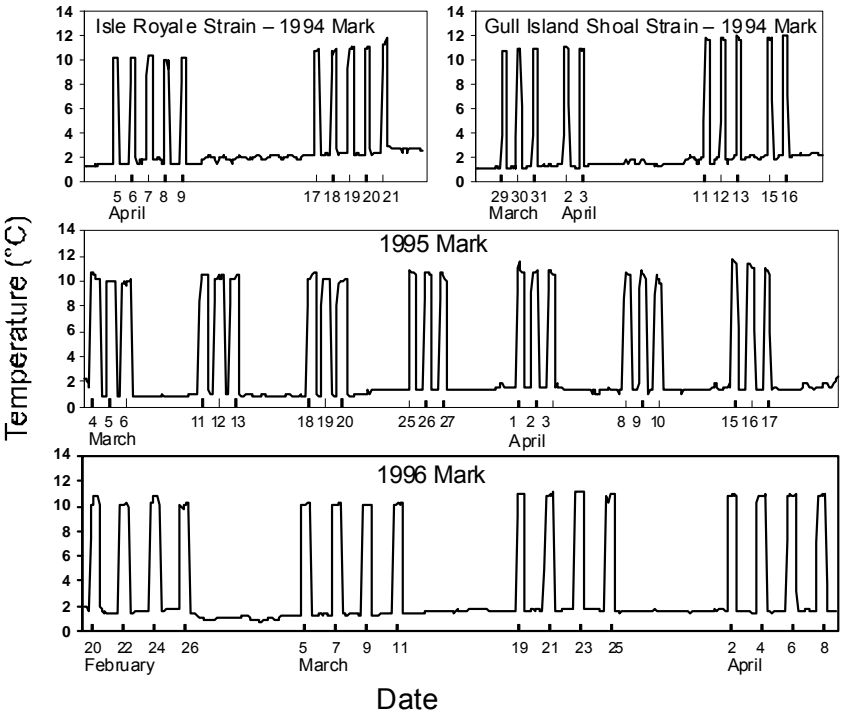

Figure 2. Temperature regimes used to mark lake trout sac fry during the production runs in 1994-1996 (Negus 1999).

Thermal marking of otoliths has become an accepted technique for mass marking early life history stages of Pacific salmon *Oncorhynchus spp.*, and is being used in Washington and Alaska on a production scale for identification and management of stocks (Blankenship and Volk 1991; Munk et al. 1993; Volk et al. 1994; Hagen et al. 1995). Mark retention in these fish has been confirmed up to 5 years. Thermal marks were applied to lake trout in earlier studies, but the recapture of these fish after stocking was never confirmed (Bergstedt et al. 1990; Brothers 1990; Bouchard 1994). The slow growth, longevity of lake trout, and cold temperatures occupied by this species can make thermal mark application and identification especially challenging (Negus 1999).

The 1994-1996 year-classes of lake trout were among those captured in assessment nets set annually from 2000 to 2002, which provided an ideal opportunity to look for thermal marks in the otoliths routinely removed from unclipped fish. The objectives of this study were to examine a representative sample of otoliths from unclipped lake trout in order to evaluate the contribution of thermally marked fry to the population of juvenile lake trout in the vicinity of Sve's Reef, and to develop expedient and practical methods for otolith mounting and grinding.

Methods

Otolith Recovery, Aging, and Mark Retrieval

Minnesota Department of Natural Resources (MNDNR) Lake Superior Area personnel removed the sagittal otoliths from unclipped lake trout captured in assessment gill nets at Sve's Reef and nearby areas from 2000 to 2002 (Table 1; Figure 1). Spring and fall large mesh gill nets, and summer small mesh gill nets were set annually; late fall spawning assessment nets were set in odd-numbered years. Otoliths were stored in scale envelopes, and later cleaned by soaking in bleach for about one hour, then rinsed in water. Otoliths from fish within the size ranges expected for the 1994-1996 year-classes were examined for thermal marks (Figure 3).

One otolith from each fish was embedded sulcus-side up in epoxy on a plastic peg (8 mm diameter by 12 mm length), cured at least 1 hour at about 40-50°C, and left overnight at room temperature. The embedded otolith was ground using a grinding/ polishing machine with FEPA¹ standard 1200 grit silicon carbide wet grinding paper. An age determination was made after partial grinding, and then grinding was continued until the core of the otolith was visible under a dissecting microscope. The epoxy chip containing the half-ground otolith was separated from the peg using a scalpel, the ground side of the otolith was attached to a glass slide with more epoxy, cured at least one hour at about 40-50°C, and left overnight. The other side of the otolith was then ground until a transparent thin section containing the otolith focus could be examined for the presence of thermal marks using a compound microscope with transmitted light. The second otolith from each fish was used for mark confirmation if necessary, but most were used for independent age determinations by another person using the crack-and-burn technique (Schreiner and Schram 2001).

Thermal marks were identified based on the three patterns of thermal treatment used in 1994, 1995, and 1996 (Figure 2). Banding patterns and placement within the otolith were compared to those in reference otoliths from fry of those year-classes. All otoliths were examined for thermal marks regardless of initial age determination. Age determinations were later compared with those determined by crack-and-burn, and proportions of thermally marked fish were determined for each of the three year-classes (Table 2).

Embedding Media and Otolith Preparation Evaluation

Embedding media, release compounds, and methods of holding the otolith samples were evaluated to determine the most effective means of otolith preparation. Six

¹ FEPA (Federation of the European Producers of Abrasives) standard 1200 grit is equivalent to U.S. grain number 600 grit, with a grain diameter of 14 microns.

Table 1. Lake trout otoliths examined for thermal marks from 2000-2002. Assessment crews were either commercial fishermen (CF) or Minnesota Department of Natural Resources Lake Superior Area personnel (LSA). Large mesh and small mesh assessments were conducted annually; spawning assessments were conducted in odd-numbered years only.

Capture location	Season	Gill net assessment	Assessment crew	Number of fish
Sve's Reef	spring (May)	large mesh	CF	439
Beaver Bay	spring (May)	large mesh	CF	130
Sve's Reef	summer (July-August)	small mesh	LSA	77
Encampment Island	summer (July-August)	small mesh	LSA	18
Silver Bay	summer (August)	small mesh	LSA	34
Sve's Reef	fall (September)	large mesh	CF	90
Beaver Bay	fall (September)	large mesh	CF	46
Sve's Reef	late fall (November)	spawning	CF	2
TOTAL				836

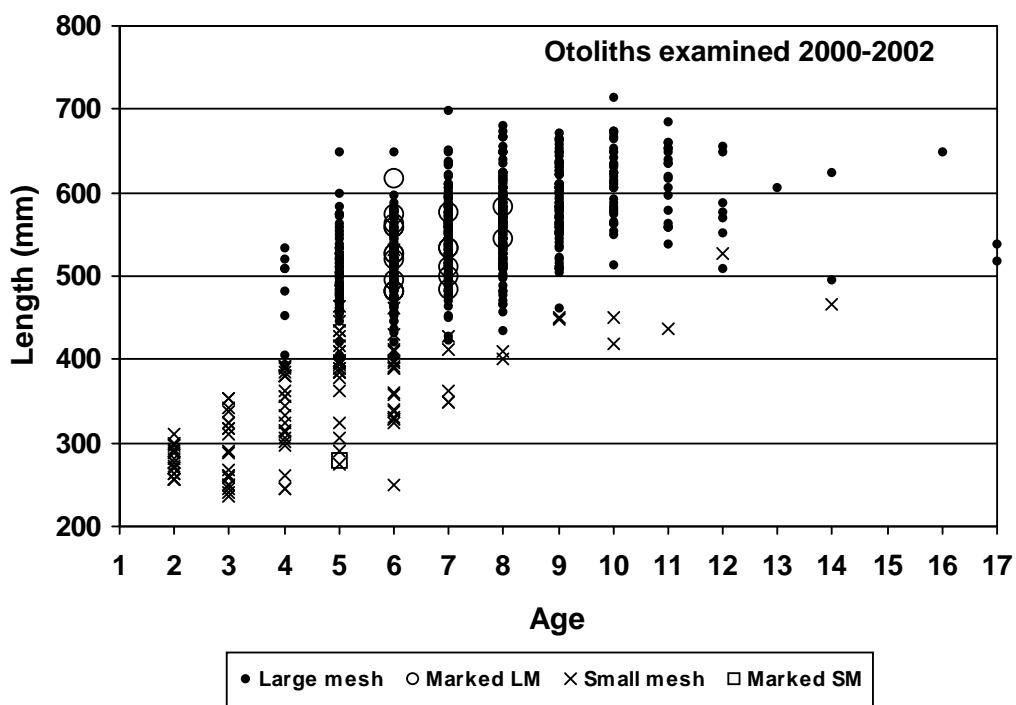

Figure 3. Otoliths examined from 2000 to 2002, including those from fish captured in small mesh (SM) and large mesh (LM) assessment nets. Fish in the 1994 to 1996 year-classes ranged from age 4 to age 8 during this study.

types of embedding media were evaluated for color, clarity, embedding and grinding properties, and ease of handling (Table 3). The evaluation included all phases of grinding both sides of an otolith. Each type of embedding material was placed on plastic pegs, allowed to harden, partially ground, cracked off the peg, reattached to a glass slide, and partially ground on the other side.

Three types of release compounds (mineral oil, microscope immersion oil, and mold release compound) were evaluated on the plastic pegs used for grinding large otoliths. A thin layer of test material was wiped onto each peg before the epoxy was dropped onto its surface. Ideally, the test material should not interfere with otolith grinding, but should allow the remaining epoxy and otolith section to be removed easily from the peg.

Three methods of holding glass microscope slides were evaluated for use on a grinding/polishing machine with a 250 rpm, 200 mm diameter polishing disc. These methods included holding the slides by hand, affixing a small suction cup (22 mm diameter) to the back of the slide, or using a slide holder fashioned from blocks of plastic and stainless steel pins (Figure 4).

Validation of Thermal Mark Retrieval Techniques

Lake trout from the 1992 thermal marking pilot study (Negus 1997) were reared in tanks for periodic sampling. Unlike many hatchery stocks, these reference fish were maintained in ambient-temperature water, usually a mixture from Lake Superior and French River. Otoliths from two of these fish sacrificed in March 1998 at age 6, and from 10 fish sacrificed in November 2000 at age 8 were used in a blind test to determine the accuracy of aging, and rate of mark recognition. Twenty-two marked otoliths were randomly mixed with 49 similarly sized otoliths taken from clipped lake trout captured in October 2001. The otoliths were mounted in epoxy, renumbered, and identifying cross-reference numbers were kept on file. Each otolith was ground on one side and aged, and aging data were filed. Ages were determined without knowledge of fish size or mortality date. Each otolith was then ground on the other side and examined for thermal marks, without reference to aging data. Finally, the age and mark determinations were cross-referenced with file data.

Table 2. Year-classes of lake trout sampled and numbers of those with thermal marks from all locations, and those found at Sve's Reef alone. Thermally treated fry were only stocked in 1994, 1995, and 1996.

Year class	Fish from all locations ^a	Number marked from all locations ^a	Percent marked from all locations ^a	Fish from Sve's Reef	Number marked from Sve's Reef	Percent marked from Sve's Reef
≤1991	47			30		
1992	85			69		
1993	152			122		
1994	211	9	4.3%	165	8	4.9%
1995	119	7	5.9%	82	4	4.9%
1996	78	5	6.4%	52	4	7.7%
1997	80			48		
1998	24			12		
1999	19			14		
unknown	21			14		
TOTAL	836	21	5.2% ^b	608	16	5.4% ^b

^a All locations include Sve's Reef, Beaver Bay, Encampment Island, and Silver Bay.

^b Percent marked among the 1994, 1995, and 1996 year classes.

Table 3. Evaluation criteria for otolith embedding media.

Embedding medium	Curing temperature; time	Color, clarity, bubbles	Holding and grinding qualities	Ease of handling	Final evaluation
Hillquist thin section epoxy	~60°C, overnight	slightly yellow, clear, some bubbles	good consistency, sometimes difficult to move bubbles	good	good
Specifix-40 epoxy from Struers	~60°C, overnight	colorless, clear, few bubbles	good consistency, very liquid for fair amount of time	good	very good
Epofix epoxy from Struers	room temperature, overnight	slightly yellow opaque, oily	epoxy appeared to separate with oil globules; inconsistent	difficult	poor
Super Glue	room temperature, <1 hour	colorless, clear, few bubbles	good consistency, but sample separated from glass slide several times resulting in lost samples	good	poor
Crystalbond 509 thermoplastic cement from Aremc	melts at 75°C, immediately firm at room temp.	slightly yellow, clear	good consistency at high temperature, quick hardening at lower temperature	difficult ^a	fair

^a Manipulation of the otoliths under the microscope was difficult with this material, which began to set-up as soon as it was removed from a hot plate.

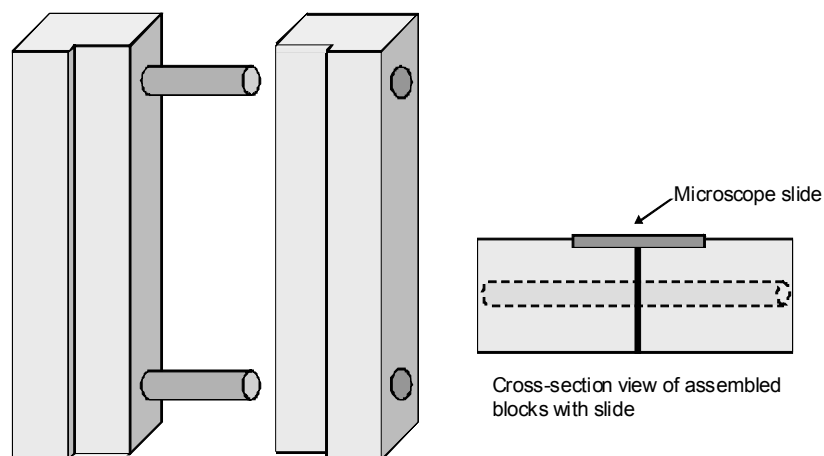

Figure 4. Slide holder made from hard plastic blocks and stainless steel pins. The pins embedded in the left block fit smoothly into holes in the right block to hold a microscope slide tightly in the depressed portion of the two blocks. The depression is slightly shallower than the thickness of a microscope slide, and the length of the blocks is equal to that of a microscope slide.

Results

Embedding Media and Otolith Preparation Evaluation

Specifix-40¹, purchased from Struers, was fairly easy to use, produced good specimens with few bubbles, and bonded well with the plastic pegs or glass slides used to hold the samples. The other types of media were less satisfactory due to yellow color, difficult handling, or poor bonding (Table 3). Results of trials using various release compounds were inconsistent; some specimens released well, others did not. The most consistent results were obtained by simply polishing the surface of each peg using very fine sandpaper on the grinder prior to epoxy application. This removed the etched surface that created an excessively tight bond between the peg and epoxy, and allowed the embedded sample to be removed easily. The slide holder (Figure 4) was found to be the best method for holding microscope slides firmly and safely, with less chance for contact with broken glass, less gouging of sandpaper, and less fatigue than the other methods. Use of the small suction cup affixed to the back of the slide was adequate, but allowed some gouging and fatigue. The entire embedding, grinding, and examination process was done over a period of three days due to overnight curing times for the epoxy.

Otolith Aging and Mark Retrieval

Age determinations from the sagittal sections were tentative, due to the difficulty in visualizing the first annulus, the tendency to grind off annuli at the edge before the center was visible, and the appearance of confounding detail between annuli. Therefore, each otolith was examined for thermal marks regardless of age assignment. The preliminary age determinations were consistent with the observed banding patterns present on otoliths from 20 of the 21 fish with observed thermally marked marks, and within one year for the remaining marked fish. The size range of lake trout examined was sufficient to include the 1994-

1996 year-classes (age 4 to age 8 fish) captured from 2000 to 2002, but there was considerable size overlap between year-classes of this slow-growing species (Figure 3). About 50% of the fish sampled were members of the target year-classes (Table 2).

Thermal marks were found in 5.4% of the 1994 through 1996 year-classes of unclipped lake trout, and the percentages of marked fish at Sve's Reef were similar to those at all nearby locations combined (Table 2). Thermally marked fish were only recaptured at Beaver Bay and Sve's Reef, but fish from these locations comprised 85% of the fish examined (Table 1). Of the nine thermally marked fish from the 1994 year-class, relative placement of the thermal bands revealed that three were Isle Royale strain, four were Gull Island shoal strain, and two were difficult to classify. Fish from the 1995 year-class were not classified as marked unless at least one set of three bands could be distinguished within the series of regularly spaced dark marks. Three fish from the 1995 year-class had possible, but unconfirmed marks, so these fish were excluded from the recaptured set.

Validation of Thermal Mark Retrieval Techniques

Eleven of the 72 otoliths (15%) examined in the aging and mark retrieval trial contained vaterite crystalline formations that made age determinations questionable or impossible. Even in the otoliths with normal calcium carbonate structure, the annuli appeared somewhat different from those in naturally reproduced or fry-stocked fish, because these otoliths came from fish that spent between one and eight years in the hatchery. The presence or absence of the 1992 thermal mark was correctly determined for all but two otoliths, and both of these otoliths came from the same tank-reared reference fish. Age designations were within 0 to 1 year of the actual age for 45 (69%) of the 65 otoliths examined. Eighteen (28%) of the age determinations were two to three years different from the actual age. Seventy of the otoliths came from fish killed between mid-September and late November, but otoliths were aged without

¹ Reference to trade names does not imply endorsement by the Minnesota Department of Natural Resources.

knowledge of capture date, assuming that the edge represented an annulus.

Discussion

The retrieval of thermal marks from lake trout remains a labor-intensive and exacting process. Otolith preparation and examination was expedited with new embedding and grinding materials, but variations in otolith size, crystalline formations, and minute target areas necessitated individual handling and preparation. Two half-ground otoliths could be ground simultaneously on opposite ends of a microscope slide for most of the second grind, but often one otolith required more grinding than the other to reach the ideal depth for examination.

Visibility of the thermal marks used in 1994 through 1996 varied somewhat. A portion of the 1994 year-class was stocked prematurely, with large yolk sacs and only one set of five thermal bands, and these fry sustained higher immediate mortality than fry stocked at a later stage (Negus 1998). No recaptures of the prematurely stocked fish were confirmed. The percentage of thermally marked fish identified from the 1994 year-class was lower than the percentages from the 1995 and 1996 year-classes, but the 1994 year-class of unclipped (naturally reproduced) fish appears to have been exceptionally large (Table 2). Tight spacing of the three bands in each set of 1995 thermal marks made differentiation of the bands difficult and mark confirmation tentative in some cases. Few examples of marked 1996 year-class fish were seen, but this year-class comprised less than 10% of the recaptures and was not fully recruited to the large mesh assessment nets. Despite occasional uncertainty in mark identification, the agreement between age determinations and thermal marks recovered from 1994 to 1996 year-class fish adds validity to the mark identifications.

Mark recognition trials using hatchery-reared thermally marked fish and recaptured clipped fish suggested a high degree of reliability in thermal mark identification, so the rate of thermal mark recovery from unclipped fish was considered to accurately represent the contribution of fry-stocked fish in this study. Because temperature fluctuations of sufficient magnitude have been found to be 100% effec-

tive for marking lake trout fry (Negus 1999), because both misidentified otoliths in these trials came from the same fish, and because follow-up examination of these otoliths still did not reveal a thermal mark, I concluded that the otoliths came from a misplaced unmarked control fish. This mark recognition exercise provided only a rough estimate of mark recovery, because mark recognition can depend on mark quality, which varied from 1994 to 1996, and only marked fish from the 1992 pilot study were reared long-term in a hatchery tank. Age determinations were considerably less accurate in these trials, partly due to the lack of adjustment for growth after the last annulus, and possibly due to a modified appearance in otoliths from fish reared in a hatchery for at least one year.

Recaptured thermally marked fish represented 5.4% of the population of unclipped juvenile lake trout in the 1994 through 1996 year-classes captured in areas near Sve's Reef from 2000 to 2002. Thermal marking enabled positive identification of these fry-stocked fish, confirming that lake trout stocked at an early life history stage can survive and contribute to existing populations. If thermal marking had not been employed, the contribution of fry-stocked fish in the target year-classes might have been misinterpreted due to an exceptionally strong 1994 year-class of unclipped fish, and relatively weak 1995 and 1996 year-classes. Stocking early life history stages has been investigated in Wisconsin using lake trout eggs, but the contribution of these unmarked fish had to be inferred based on year-class-specific stock recruitment analysis and comparisons with populations in adjacent unstocked areas (Bronte et al. 2002).

Little is known about the extent of movement by juvenile lake trout, but travel up to or exceeding 80 km was not unusual for adult lake trout in Lake Michigan (Schmalz 1999). Sampling for marked otoliths in this study was confined to locations within 15 km of the stocking site, assuming that the concentration of juvenile thermally marked fish would be highest in these areas. Although 75% of lake trout mature by age 8, a November spawning assessment was not conducted in 2002, so most of the fish sampled from the target year-classes were immature during this study. Lake trout will migrate back to their

site of initial imprinting to spawn (Marsden et al. 1995), so if the thermally marked fry imprinted to the reef where they were stocked, a higher percentage of thermally marked fish may be captured in spawning assessment nets set in 2003 and later. Examination of otoliths from unclipped mature lake trout through at least 2007 will enable an evaluation of their contribution to spawning populations at Sve's Reef. Further examination of archived otoliths taken from unclipped juvenile lake trout captured farther from the stocking reef may also reveal information regarding movement by the young fish after stocking.

References

- Bergstedt, R. A., R. L. Eshenroder, C. Bowen, J. G. Seelye, and J. C. Locke. 1990. Mass-marking of otoliths of lake trout sac fry by temperature manipulation. *American Fisheries Society Symposium* 7:216-223.
- Blankenship, H. L., and E. Volk. 1991. Effects of coded-wire tagging on the survival of spring chinook salmon. Washington State Department of Fisheries. Annual Report FY-1990-91, Project No.88-163, Olympia.
- Bouchard, L. 1994. Expérimentation de thermo- marquage d'otolithes de touladi. Centre Écologique du Lac St-Jean inc. Rapport présenté à la Vice-présidence Environnement, Hydro-Québec, Saint-Félicien, Québec, Canada.
- Bronte, C. R., S. T. Schram, J. H. Selgeby, and B. L. Swanson. 2002. Reestablishing a spawning population of lake trout in Lake Superior with fertilized eggs in artificial turf incubators. *North American Journal of Fisheries Management* 22:796-805.
- Brothers, E. B. 1990. Otolith marking. *American Fisheries Society Symposium* 7:183-202.
- Hagen, P., K. Munk, B. Vanalen, and B. White. 1995. Thermal mark technology for inseason fisheries management: a case study. *Alaska Fishery Research Bulletin* 2:143-155, Juneau.
- Marsden, J. E., J. M. Casselman, T. A. Edsall, R. F. Elliot, J. D. Fitzsimons, W. H. Horns, B. A. Manny, S. C. McAughey, P. G. Sly, and B. L. Swanson. 1995. Lake trout spawning habitat in the Great Lakes - a review of current knowledge. *Journal of Great Lakes Research* 21 (Supplement 1):487-497.
- Munk, K. M., W. W. Smoker, D. R. Beard, and R. W. Mattson. 1993. A hatchery water-heating system and its application to 100% thermal marking of incubating salmon. *The Progressive Fish-Culturist* 55:284-288.
- Negus, M. T., and D. J. Dexter. 1995. A compact, inexpensive, automatic system to deliver water at alternating temperatures for hatchery studies. *The Progressive Fish-Culturist* 57: 315-319.
- Negus, M. T. 1997. Thermal marking of lake trout otoliths, and evaluation of methods for stocking fry. Minnesota Department of Natural Resources Division of Fisheries, Investigational Report 457.
- Negus, M. T. 1998. Evaluation of stocking methods for lake trout fry. *Journal of Great Lakes Research* 24:969-973.
- Negus, M. T. 1999. Thermal marking of otoliths in lake trout sac fry. *North American Journal of Fisheries Management* 19:127-140.
- Schmalz, P. J. 1999. Movement of adult lake trout tagged in northwestern Lake Michigan. MS Thesis, University of Wisconsin, Stevens Point.
- Schreiner, D. R., and S. T. Schram, editors. 2001. Lake Superior Fish Aging Manual. Great Lakes Fishery Commission Miscellaneous Publication, Ann Arbor, Michigan.
- Volk, E. C., S. L. Schroder, and K. L. Fresh. 1990. Inducement of unique otolith banding patterns as a practical means to mass-mark juvenile Pacific salmon. *American Fisheries Society Symposium* 7:203-215.
- Volk, E. C., S. L. Schroder, J. J. Grimm, and H. S. Ackley. 1994. Use of a bar code symbology to produce multiple thermally induced otolith marks. *Transactions of the American Fisheries Society* 123:811-816.